

amount of belt drive units: 2 - 4 pcs.

pitch: 70 - 540  
customizable

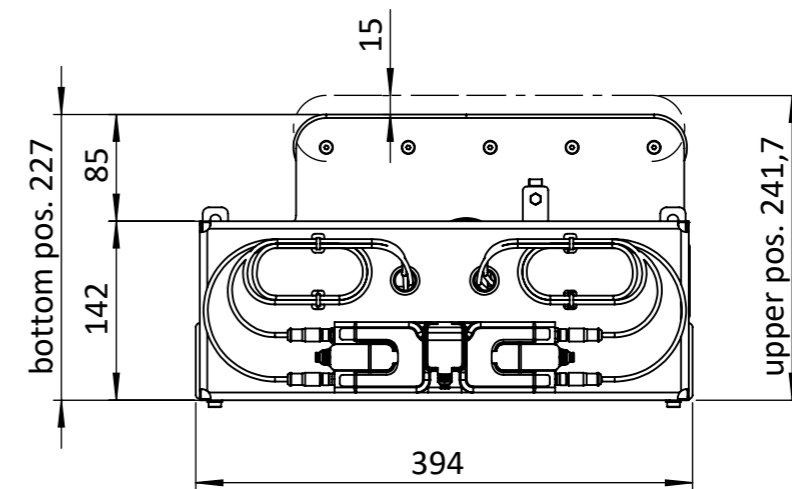
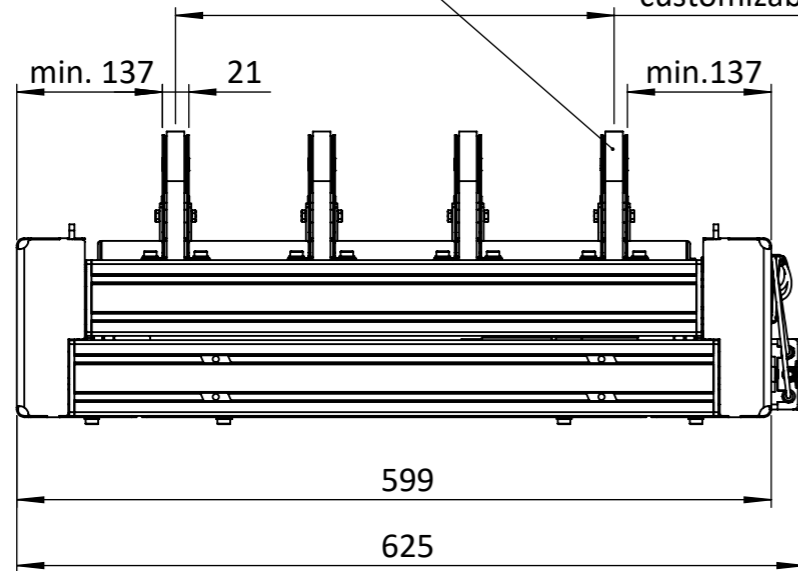

Drawing is owned by Flowsort BV, all rights reserved.  
Multiplication, inspection or notifications to third parties  
in any possible form, is not permitted without written  
permission from Flowsort BV.

Flowsort BV, Rudolf Dieselweg 14, 5928 RA Venlo, The Netherlands  
+31(0)85-0761339 | info@flow-sort.com | www.flow-sort.com

Tolerances unless otherwise specified:			
>0.2 to 6	>6 to 30	>30 to 120	>120
± 0.1	± 0.2	± 0.3	± 0.5

DO NOT SCALE DRAWING  
NEN-ISO 2769-mK  
Roughness: DIN ISO 1302

UNLESS OTHERWISE SPECIFIED:  
DIMENSIONS ARE IN MILLIMETERS  
Edges: N12A B42 DIN 6784

MATERIAL:  
FINISH:  
DRAWN ON: 2024. február 21., szerda 15:40:55  
BY:

TITLE  
**X-Flow90 Ver 1.1 400 S with 4 blades**

REMARK: Debur and break sharp edges  
WEIGHT: gram

DRAWING NUMBER  
**X-Flow90\_A\_Tab\_V1.1**

COPYRIGHT  
©  
RESERVED

THIRD ANGLE PROJECTION  
DATE: 2026. április 10., péntek 7:44:33  
SAVED BY: IstvánMikle

REVISION:  
SCALE: 1:6  
SHEET 1 OF 3

A3